

APPLICABLE MODELS
PA-30 AND PA-39

KNOTS 2U, INC
DORSAL FIN
INSTALLATION MANUAL
ISSUE DATE 10/15/88

KNOTS 2U, LTD.
709 AIRPORT ROAD
BURLINGTON, WI 53105
(262) 763-5100

FAA
APPROVED

NOV 18 1996

CHICAGO AIRCRAFT
CERTIFICATION OFFICE
CENTRAL REGION

REVISIONS

REV. No.	DATE	PAGE	EFFECT
I	10/25/96	ALL	Added Revisions to cover, changed installation procedures for non counter-rotating models. See Knots 2U, Inc. Report Number SA516GL for previous revisions

TABLE OF CONTENTS

SECTION		PAGE #
1.0	BASEPLATE INSTALLATION	1
1.1	Locating fin mounting position	1
1.2	Locating Dorsal Fin on fuselage	1
1.3	Locating and drilling Dorsal Fin attachment holes	1
1.4	Moving original fairing attach angles	1
1.5	Cleaning and deburring	1
1.6	Riveting baseplate and angles to fuselage	1
2.0	HIDDEN ANTENNA INSTALLATION	2
2.1	Mounting Com antennas	2
2.2	Antenna installation parts list	2
3.0	FINAL INSTALLATION OF DORSAL FIN	2
3.1	Notching baseplate for airbox	2
3.2	Securing leading edge of dorsal fin	2
3.3	Locating & drilling fin attachment holes	2
3.4	Final attachment of dorsal fin	2
4.0	PAPERWORK	3
4.1	Dorsal fin installation parts list	3
4.2	Weight and balance data	3
5.0	MAINTENANCE MANUAL	4
6.0	DETAIL #1	5
7.0	DETAIL #2	6
8.0	SUPPLEMENTAL TYPE CERTIFICATE	7

FAA
APPROVED

NOV 18 1996

CHICAGO AIRCRAFT
CERTIFICATION OFFICE
CENTRAL REGION

SECTION 1.0 BASEPLATE INSTALLATION

NOTE #1:

There are three fuselage skin seams which intersect the new dorsal fin. For the purposes of this manual we will reference the rear skin seam, the second seam forward of the front spar of the vertical fin and the forward skin seam (Station 157.0), the third skin seam forward of the front spar of the vertical fin. (see Detail #1)

1.1 LOCATING FIN MOUNTING POSITION.

Remove existing dorsal fin assembly by drilling out rivets. Remove mounting screws and existing fairing assembly. Mark a centerline on top of the fuselage by centering between the holes just drilled. Extend the line far enough forward to meet forward skin seam (STA 157). The Fin will be located on this centerline for PA-39s and PA-30s which have been Counter-rotated. The fin will be displaced .75 inches to the left at STA 157.0 on PA-30s which have normal rotating engines. (See Detail #1)

1.2 LOCATING DORSAL FIN ON FUSELAGE.

Referencing Detail #1, and using the rear skin seam, the 2nd seam forward of the front fin spar, and the marked centerline as reference, lay the baseplate **P/N BP** on the fuselage with the trailing edge 9.75 aft of the rear skin seam and properly centered through its entire length. On normal rotating PA-30s extend the centerline of the baseplate forward to STA 157 and rotate leading edge of the baseplate .75 to the left to coincide with the displaced centerline. Mark the three hole locations (one at the front and two at the rear) through the baseplate and onto the fuselage. Remove the baseplate and drill three #40 holes in these locations. Cleco baseplate in place on the fuselage and trace a line around its perimeter onto the fuselage skin. Remove baseplate and clecos.

1.3 LOCATING AND DRILLING DORSAL FIN ATTACHMENT HOLES.

Drill out all roundhead rivets within the baseplate perimeter which will interfere with the proper fit of the baseplate. Cleco baseplate into position and from inside the fuselage bay, using the holes just drilled, mark the locations onto the baseplate. Remove baseplate and drill marked locations. Cleco baseplate in place and referencing Detail #1 drill the remaining attachment holes through baseplate and fuselage, cleco as you go. Check the air hole in the baseplate. It must not cover any of the air hole in the fuselage. Trim Baseplate air hole, as needed, to clear.

1.4 MOVING ORIGINAL FAIRING ATTACH ANGLES.

Drill out rivets attaching the 2 angles which were used as attach points for the original dorsal fin. Using a straight edge extend left and right edges of baseplate aft and mark and reposition the angles .625 (nominal) outboard to match the extended lines. Mark new hole locations onto the fuselage through the existing angle holes. Drill to #30 hole size.

1.5 CLEANING AND DEBURRING.

Deburr all holes and clean shavings from aircraft. Corrosion proof all holes in angles, fuselage and baseplate, with alodine solution or equivalent.

1.6 RIVETING BASEPLATE AND ANGLES TO FUSELAGE.

Cleco baseplate and angles to fuselage. Using **P/N CR3243-4-2** rivets, rivet baseplate in place remove clecos as you go. Also, rivet angles into place and fill original angle attachment holes. Seal edges of baseplate to fuselage and any open areas using RTV.

/ F A A

A P P R O V E D

NOV 18 1996

SECTION 2.0 HIDDEN ANTENNA INSTALLATION.

2.1 MOUNTING COM ANTENNAS

Install antennas per Detail #2 and Dorne & Margolin templates and Installation Instructions.

2.2 ANTENNA INSTALLATION PARTS LIST.

PART NUMBER	NO. REQ	DESCRIPTION
DM C63-1/A	2	Dorne/margolin antenna
MS24693C274	6	Screw
MS20365C1032A	6	Locknut
MS35335-60	6	Lockwasher

FAA
APPROVED
NOV 18 1996

SECTION 3.0 FINAL INSTALLATION OF DORSAL FIN.

CHICAGO AIRCRAFT
CERTIFICATION OFFICE
CENTRAL REGION

3.1 NOTCHING BASEPLATE FOR AIRBOX.

Referring to Detail #1 place fin on top of baseplate and mark the areas where the baseplate sides will interfere with the airbox and naca duct. Trim these areas on baseplate, radius all corners.

3.2 SECURING LEADING EDGE OF DORSAL FIN.

Position fin properly over baseplate and drill a #21 hole through the leading edge of the fin at a position 1" aft of the forward tip. Where the dorsal fin intersects the forward skin seam (STA 157.0) drill (2) #30 pilot holes, one centered on the flange of the fin on each side, and in line with existing rivet row. Counter sink flange holes to 100 degrees and countersink the leading edge hole to accept the *P/N DP1075-12SS Washer*. Remove fin and install (3) *P/N A6-75* rivnuts in the fuselage at these locations. Install fin and secure leading edge with a *P/N MS24693C29* screw and *P/N DP1075-12SS Washer*. Secure flanges with (2) *P/N AN507-632-R10 Screws*.

3.3 LOCATING AND DRILLING FIN ATTACHMENT HOLES.

Make sure dorsal fin is snugly fit onto the fuselage. Sand bags or an appropriate method of weight can be used to hold dorsal fin firmly onto fuselage. Beginning on the right side drill a #40 hole 1" forward of the aft end of the baseplate .50 up from the lip. Drill another #40 hole 1.5 aft of the forward edge of the baseplate .5 up from the lip. Repeat on the left side and Cleco the dorsal fin in position at these 4 locations. Using 6" (nominal) spacing move aft on the right side of the fin and drill (6) #40 holes (omitting hole at the airbox notch). Using the same hole positioning drill (7) #40 holes on the left side of fin. Cleco as you go. Referencing Detail #1 move back to the original attach angles and using a hole finder locate and drill all holes in front of the angles. Also, locate and drill all aft edge mounting holes along vertical fin.

3.4 FINAL ATTACHMENT OF DORSAL FIN.

Remove dorsal fin from baseplate. Enlarge side holes on baseplate to #16 hole size. Attach Clip nuts *P/N A1785-6Z1D* over holes. Enlarge side holes in fin to fit the *P/N DP1075-12SS* washers. Install foam tape around bottom perimeter of dorsal fin and place fin back onto fuselage. Secure in place using *P/N NAS548P6-10* screws into tinnermans clip nuts. Use supplied *P/N A3235-020-24A* washers and *P/N FHA10X3/4* screws to secure trailing edge to vertical fin and *P/N A3135-017-24A* washers and *P/N FHA8X3/4* screws to secure fin to the relocated attach angles. The edge of the fin may be sealed to the fuselage with a bead of RTV, at this time.

SECTION 4.0 PAPERWORK.**4.1 DORSAL FIN INSTALLATION PARTS LIST**

<u>PART NUMBER</u>	<u>No. REQ.</u>	<u>DESCRIPTION</u>
RDF	1	Removable Dorsal Fin
BP	1	Baseplate
189-715	16 FT	Piper Window Seal
A3235-020-24A	10	C/S Washer
FHA10x3/4	10	C/S Screw
A3135-017-24A	8	C/S Washer
FHA 8x3/4	8	C/S Screw
A1785-6Z1D	15	Tinnerman Clip Nut
DP1075-12SS	16	C/S Washer
NAS548P6-10	15	C/S Screw
MS24693C29	1	Screw
AN507-632-R10	2	Screw
A6-75	3	Rivnut
CR3243-4-2	55	Cherrymax Rivet

4.2 WEIGHT AND BALANCE DATA.

<u>COMPONENT</u>	<u>WEIGHT</u>	<u>ARM</u>
<u>REMOVED</u>		
Original dorsal fin	- .66 LBS.	188.75
Original fairing assembly	- 1.31 LBS.	213.75
<u>INSTALLED</u>		
New dorsal fin and hardware	+ 6.25 LBS.	212.00
<u>ANTENNAS:</u>		
Forward antenna & hardware	+ .50 LBS.	184.50
Aft antenna & hardware	+ .60 LBS.	223.50

Perform paperwork work (form 337 and logbook entries). Place *KNOTS 2U, INC.* Maintenance manual and supplemental type certificate with logbooks.

FAA
APPROVED

NOV 18 1996

CHICAGO AIRCRAFT
CERTIFICATION OFFICE
CENTRAL REGION

SECTION 5.0 MAINTENANCE MANUAL**KNOTS 2U, INC.****PIPER PA-30/39 DORSAL FIN****PART A. INSPECTION**

1. Daily inspection at pre-flight to, check security of dorsal fin attachment to aircraft. Also, check for any obstruction in NACA duct, or cracks in the dorsal fin.
2. During annual or 100 hour inspections inspect for obstructions in NACA duct and inspect attachment hardware for excessive wear or looseness. Check drain for obstructions.

PART B. MAINTENANCE

1. Keep NACA duct clear of obstructions.
2. If any attachment hardware is found to be excessively worn or loose during the 100 hour/annual inspection, it should be replaced.

PART C. CRACKING OR DEFECTS

1. If any cracks are found on dorsal fin, they should be stop drilled.
2. If any crack exceeds 2 inches in length; or, if a crack runs from an attachment hole to the outer edge of the dorsal fin, remove the fin and repair the crack according to FAR 43.13-1 Acceptable Methods, Techniques, and Practices - Aircraft Inspection and Repair, Chapter 2.

PIPER PA-24, PA-30 & PA-39
DORSAL FIN INSTALLATION

INSTALL (1) AN507-632-R10 SCREW AND (1) A6-75 RIVNUT, CENTERED ON FIN FLANGE, ON EACH SIDE OF FIN, ALIGNED WITH EXISTING RIVET ROW. DRILL RIVNUT HOLE TO #13 DRILL AND C/S FLANGE 100°

**FIN MOUNTING
DETAIL**

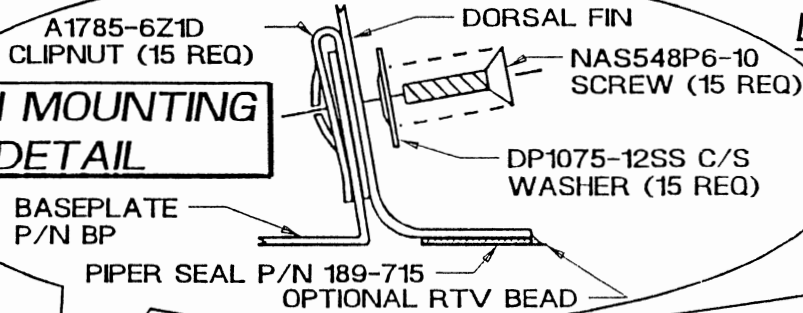

DRILL HOLES IN DORSAL TO MATCH EXISTING HOLES ON VERTICAL FIN AND ANGLES

MS24693C29 SCREW AND DP1075-12SS WASHER

1.5

.50 (MIN) 6.0 (CONSTANT)

AIR BOX

**DORSAL
P/N RDF**

THIS HOLE AND HARDWARE ELIMINATED ON RIGHT SIDE OF FIN

AIRCRAFT SKIN

**FIN & BASEPLATE
SIDE VIEW DETAIL**

BASEPLATE NOTCHED IN THIS AREA TO CLEAR AIRBOX

P/N BP

A6-75 RIVNUT

THIS SEAM IS STATION 157.0

REAR SEAT AIR INLET (SOME MODELS)

SEE SECTION 1.3 AND 1.4 OF INSTALLATION MANUAL

REFERENCE FOR FIN CENTERLINE ROTATION

ON PA-39 AND COUNTER ROTATING PA-30 AIRCRAFT INSTALL THE FIN ON THE FUSELAGE CENTERLINE

— AFT —

CR3242-4-2 RIVETS (TYP)

ON PA-24 AND NORMAL ROTATING PA-30 AIRCRAFT ROTATE FIN CENTERLINE .75 INCHES TO LEFT OF FUSELAGE C/L AT STA 157.0

**TOP VIEW OF
TAILCONE**

9.75

.625 FRONT FIN SPAR

SEE INSTALLATION MANUAL NOTE #1 'REFERENCE SKIN SEAM'

**ENLARGED VIEW OF
RIVET LOCATIONS**

9.75

DETAIL # 1 PAGE -5-

ORIGINAL FIN MOUNT HOLES

BASEPLATE OUTLINE

NOTS
K2U

X INDICATES 3 #40 HOLE LOCATIONS THAT ARE USED TO POSITION BASEPLATE. SEE SECTION 1.2

PA-24, PA-30/39 HIDDEN ANTENNA INSTALLATION DETAIL

DWG No. ANT
REVISED 11/11/95

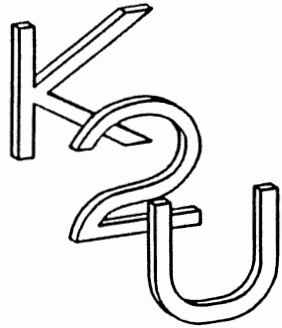

ANTENNA MOUNTING
DETAIL

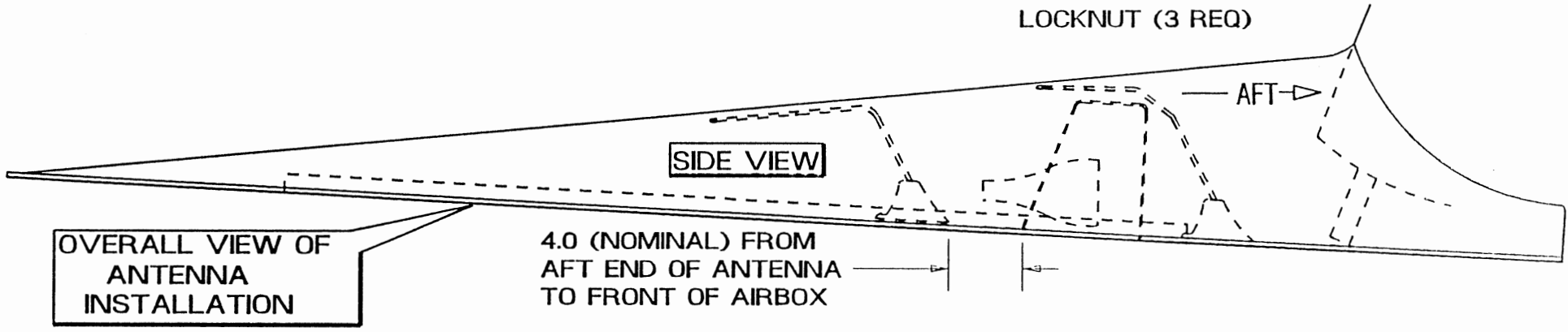
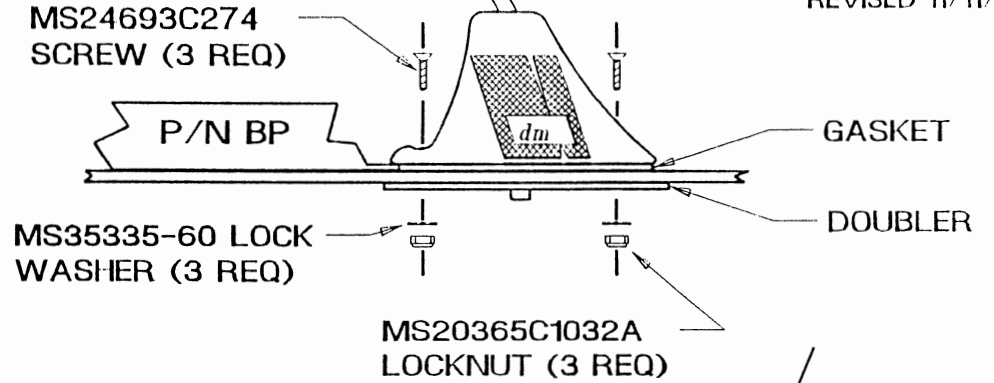

OVERALL VIEW OF
ANTENNA
INSTALLATION

REAR LIP OF AFT ANTENNA OVERLAPS
TRAILING EDGE OF BASEPLATE

